

ExAmp-20K Extracellular Amplifier

User Guide

General description

The ExAmp-20K is an AC-coupled amplifier designed for low-noise extracellular recording. Its unique headstage probe design puts the first stage of amplification at the microelectrode interface, resulting in less external interference noise pickup. The built-in filters are optimized for solid-conductor microelectrodes such as carbon fiber, tungsten or stainless steel. The included 60 Hz reject filter and our special electrode holder adapters virtually eliminate the need for Faraday cages. Possible applications are single-unit or single-axon recording, field potential, cord dorsum potential recording, bipolar electrocardiography, EMG and EEG. The direct electrode access allows passing current through the electrode or it can be used for electrochemical measurements.

Front panel controls

Power: Turns the unit on or off.
On LED: Signals power On status.
Probe In: Connects the plug of the headstage probe
Gate LED: Signals direct electrode access. Spike amplifier is grounded at the same time.
Gain: Selects the magnitude of amplification.
Signal Out: Output for the amplified signal.

Front panel view

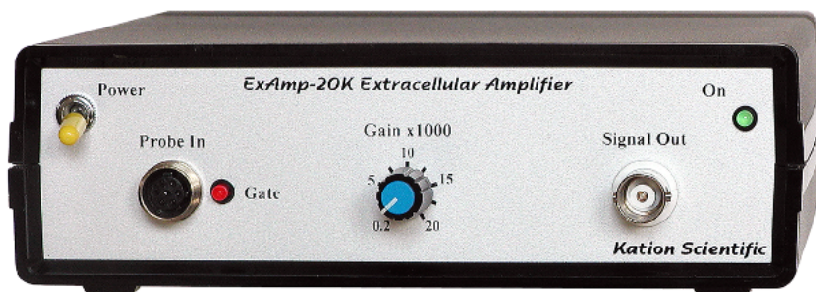

Color of parts may vary

Rear panel view



Rear panel controls

Manual/Ext.Gate: Manual switching of the 'Electrode Access' gate.
Gate In: External gating signal input. TTL or CMOS (+5V). Switching time: 1.5 ms typical, 3 ms maximum. Input is optically isolated up to 5000 V.
Electrode Access: Direct connection to the recording electrode when the Gate is activated either manually or externally through the 'Gate In' BNC input. See schematic → **DO NOT EXCEED 200 V WHEN PASSING CURRENT THROUGH THE ELECTRODE!**
Ground: System ground connector
Power In/Out: Two identical DC power jacks

Main unit specifications

Input impedance: 10 TΩ, input leakage current: 0.8 pA
Gain: Probe: 10x, System: 200x to 20,000x
Filters built-in: Two 6-pole, tuned circuit bandpass, 60 Hz reject filter (50 Hz optional)
Bandpass frequencies: 300 Hz to 8000 Hz
Output voltage swing: ±13.5 V, maximum
Power: External, 12 VDC, 75 mA power supply
DC power jacks: Rear panel, 2.1 mm x 5 mm type
Dimensions: 6 1/8"x2 1/4"x6 7/8" (155x54x175 mm)
Weight: 1.12 lb (500 grams)

Headstage probe specifications

Mounting rod: 1/4" (6.4 mm) x 4" (105 mm), diam. x length
Body: 5/32" (14.4 mm) x 2" (50 mm), diam. x length
Material: Nickel-plated brass
Cable length: 52" (132 cm)
Input sockets mate with: 0.0315"-0.0370" (0.80-0.94 mm) diam. pins

Signal routing

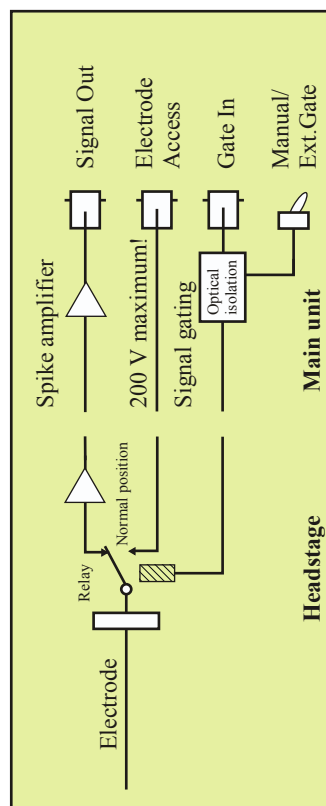

Headstage probe

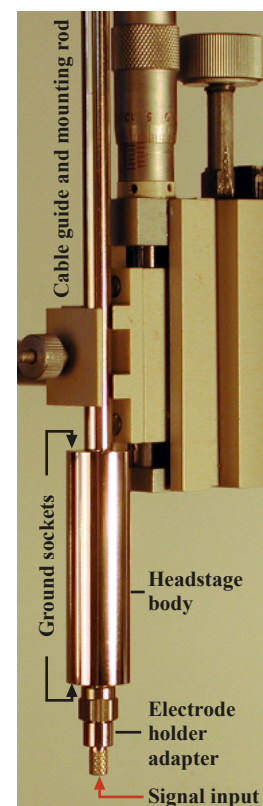

Micromanipulator is for illustration only

Kation Scientific, P.O. Box 14674, Minneapolis, MN 55414 Phone/Fax: (651) 698-5167.

E-mail: info@kationscientific.com Web: www.kationscientific.com

Performing an experiment

In order to minimize external noise pickup and interference, experimental set-ups have to be correctly shielded and grounded. Overall shielding is often provided by a Faraday cage. Faraday cages do not necessarily remove interference from magnetic fields which usually cause the most problems. Here we provide a few tips to improve quality of recordings.

Tip 1. Place the the preparation to be recorded as close to a large iron steel (not stainless steel!) baseplate as possible (which should be connected to the ground pin of the headstage probe). The greater the mass of the plate, the more helpful it will be at deflecting a magnetic field. A steel slab 1/2" (12 mm) thick and at least 20" (500 mm) on each side greatly improves the quality of extracellular recordings.

Tip 2. Always keep the lead wire from the electrode to the headstage probe (or to the animal's foot when used as an electrocardiograph) as short as possible, less than 2" (5 cm). This is accomplished by our unique headstage probe design so that microelectrodes can actually be plugged straight into the probe. See figures →

Tip 3. Keep line-powered equipments as far away from the site of recording as it is possible. Everything near the preparation should be grounded to a single point, that is the ground pin on the headstage probe and to nothing else. Use of a "star" formation grounding will minimize ground loops.

After following these basic rules, the removal of interference noise is normally a process of trial and error, involving experiments with slightly different patterns of grounding and shielding. Remember that our ExAmp-20K amplifier permits a very smooth, low-noise recording. Thus, if your extracellular recording shows a frustrating level of noise keep trying to find and eliminate the source.

Electrode holder adapters

Two types of electrode holders are offered for our headstage probes. The first is used for attaching Kation-made single or multibarreled carbon fiber electrodes to the headstage. In order to configure this type of electrode holder, screw the adapter onto the headstage and simply plug the electrode's connector pin in as shown in the leftmost diagram. The other type of adapter is used for accomodating long, small-diameter metal electrodes. To configure this type of electrode holder, first insert the electrode pin—first into the front of the adapter and pull it through so that it protrudes somewhat from the back end of the adapter. Use a small tweezers to grasp the pin of the electrode and insert it into the input socket of the probe. Screw the adapter onto the probe gently by hand. Finally, take an inch-long strip of electrical tape and roll it cylindrically so that one-third of the tape's width is around the front end of the adapter and two-thirds of it is around the shank of the electrode itself, then flatten the front end of the tape using the thumb and forefinger. The end result of this procedure is illustrated in the rightmost diagram.

Power supply

The international power adapter that Kation Scientific offers (Cat#: M1116) can provide power for several of our instruments provided that their combined current consumption does not exceed the adapter's limit. Use our DC power cable to a daisy-chain multiple units as shown.

Grounding

An extra grounding input is provided by the miniature banana jack on the back panel. This is on the same potential as the shells of the input and output connectors and the grounding sockets of the headstage probe and metal parts of the headstage itself. Note that the circuitry of the ExAmp-20K is galvanically isolated from the DC power inputs.

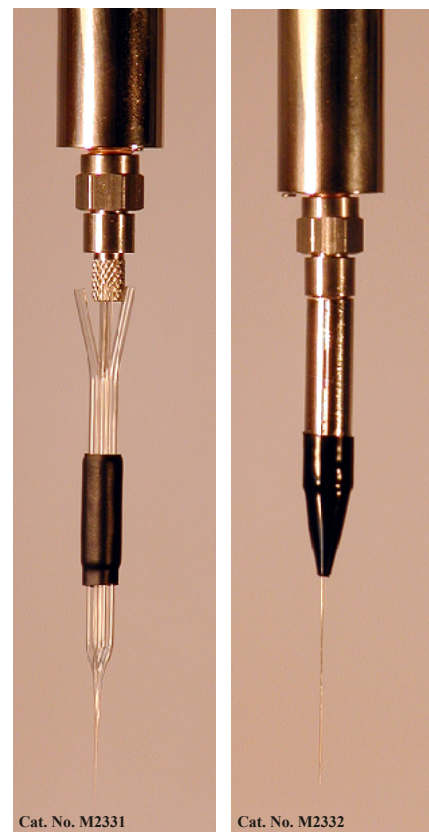

Cat. No. M2331
Adapter for Kation-made single and multi-barreled electrodes

Cat. No. M2332
Metal electrode adapter

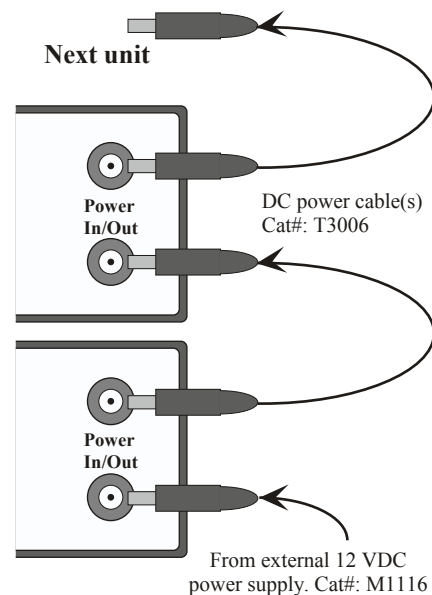

Daisy chained power supply formation for multiple units

Certification:

Kation Scientific certifies that this instrument has been tested and inspected thoroughly and was found to meet all published specifications before shipment from the factory.

Warranty:

This product is warranted against defects in materials and workmanship for one full year from the date of shipment as long as it has been exposed to normal and proper use. Products which prove to be defective during the warranty period will be repaired or replaced without charge provided they are returned to the factory. Kation Scientific will provide for servicing and calibration after the warranty period for a reasonable service charge. The instrument should be shipped to the factory postage prepaid.